

1. In an experiment, males and females of different species of fruit fly, *Drosophila*, were kept together. Male fruit flies show complex courtship behaviour before they attempt to mate. The table shows the percentage of females that mated when kept with males of different species.

Females	Males	Percentage of females that mated
<i>D. serrata</i>	<i>D. serrata</i>	90.2
<i>D. serrata</i>	<i>D. birchii</i>	0.7
<i>D. serrata</i>	<i>D. dominicana</i>	1.3
<i>D. birchii</i>	<i>D. birchii</i>	76.9
<i>D. birchii</i>	<i>D. serrata</i>	1.0
<i>D. birchii</i>	<i>D. dominicana</i>	0.4
<i>D. dominicana</i>	<i>D. dominicana</i>	93.0
<i>D. dominicana</i>	<i>D. serrata</i>	0.0
<i>D. dominicana</i>	<i>D. birchii</i>	3.7

- (a) In the classification of fruit flies, which biological subdivision is represented by the name *Drosophila*?

.....

(1)

- (b) (i) What do the data show about the mating preference of female *Drosophila*?

.....

.....

(1)

- (ii) Suggest an explanation for this mating preference.

.....

.....

.....

.....

(2)

- (iii) Suggest how these three species of *Drosophila* might have evolved from a common ancestor.

.....

.....

.....

.....

(3)  
(Total 7 marks)

2. The table gives some of the groups into which the buttercup, *Ranunculus bulbosus*, is classified.

Name of group	Group	Sequence
Angiospermophyta	Phylum	
bulbosus	Species	
Dicotyledoneae	Class	
Ranales		
Ranunculaceae	Family	
Ranunculus	Genus	

Complete the table, as follows.

- (i) Give the name of the missing group in column 2. (1)
- (ii) Write the numbers 1 to 6 in column 3 to show the correct sequence of the groups, where 1 is the largest group and 6 is the smallest. (1)

(Total 2 marks)

3. (a) What is meant by the term *species*?

.....  
 .....

(2)

- (b) List the following taxonomic groups in sequence according to the number of species they contain. Start with the group with the greatest number of species.

	<b>class</b>	<b>family</b>	<b>genus</b>	<b>kingdom</b>	<b>order</b>	<b>phylum</b>
1	.....					
2	.....					
3	.....					
4	.....					
5	.....					
6	.....					

(1)

- (c) Give **one** way in which cells from members of the kingdom Prokaryotae differ from those of all other kingdoms.

.....

(1)

**(Total 4 marks)**

4. The table shows some results from a study of the transfer of energy in some primary consumers in a grassland ecosystem. All figures are in arbitrary units.

Amount of energy	Type of organism	
	mammals	insects
consumed in food (C)	25.00	4.00
absorbed from the gut (A)	12.50	1.60
in faeces (F)	12.50	2.40
in new body mass (P)	0.25	0.64
lost in respiration (R)	12.25	0.96

- (a) (i) The ratio of the amount of energy lost in respiration to the amount of energy consumed in food in the mammals is 0.49 : 1. Calculate the ratio of the amount of energy lost in respiration to the amount of energy consumed in food in the insects.

Answer .....

(1)

- (ii) Suggest an explanation for the difference between these two ratios.

.....

.....

.....

.....

(2)

- (b) Use the letters C, F and P to complete the equation

R = .....

(1)

- (c) A higher proportion of the energy consumed in food is absorbed from the gut in secondary consumers than in primary consumers. Suggest an explanation for this.

.....  
 .....

(1)  
 (Total 5 marks)

5. The diagram shows some of the stages in two processes that produce ATP.

**Process 1**

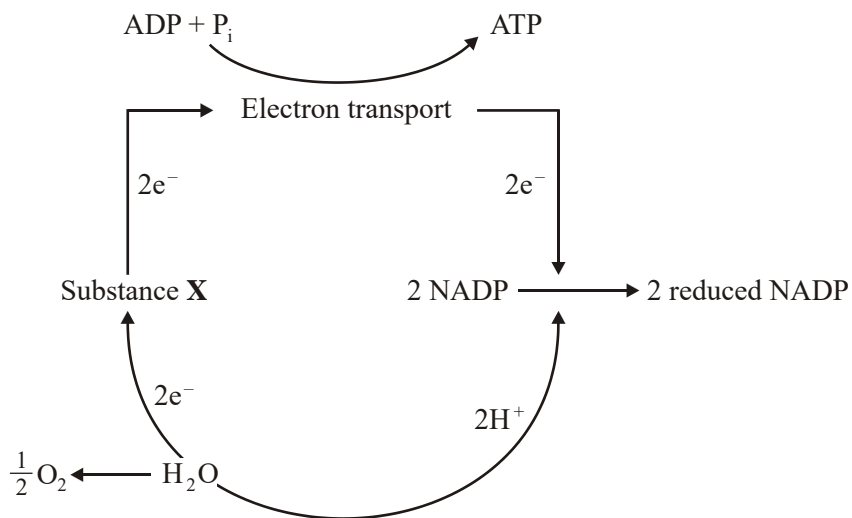

**Process 2**

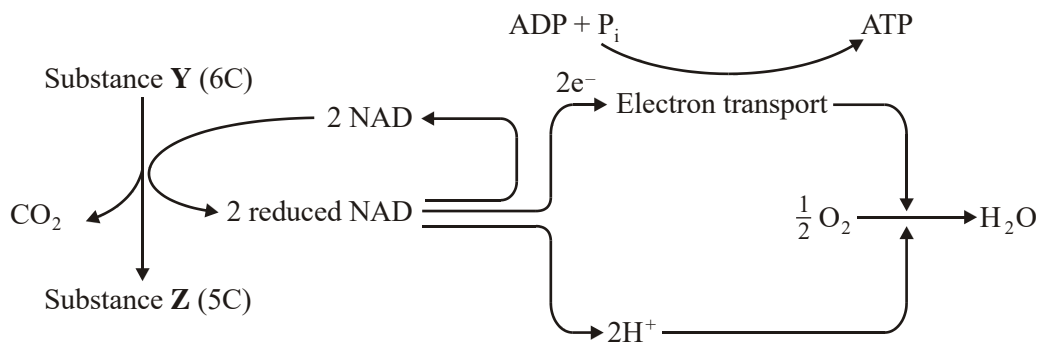

- (a) In **Process 1**, what causes substance **X** to lose electrons ( $e^-$ )?

.....  
.....

(1)

- (b) Where precisely, within a cell, does electron transport take place in **Process 2**?

.....  
.....

(1)

- (c) Name **one** kingdom which contains organisms that can produce ATP using both processes. Explain your choice.

.....  
.....  
.....  
.....

(2)

(Total 4 marks)

6. Armadillos are mammals. The map shows the ranges of three species of armadillo in South America.

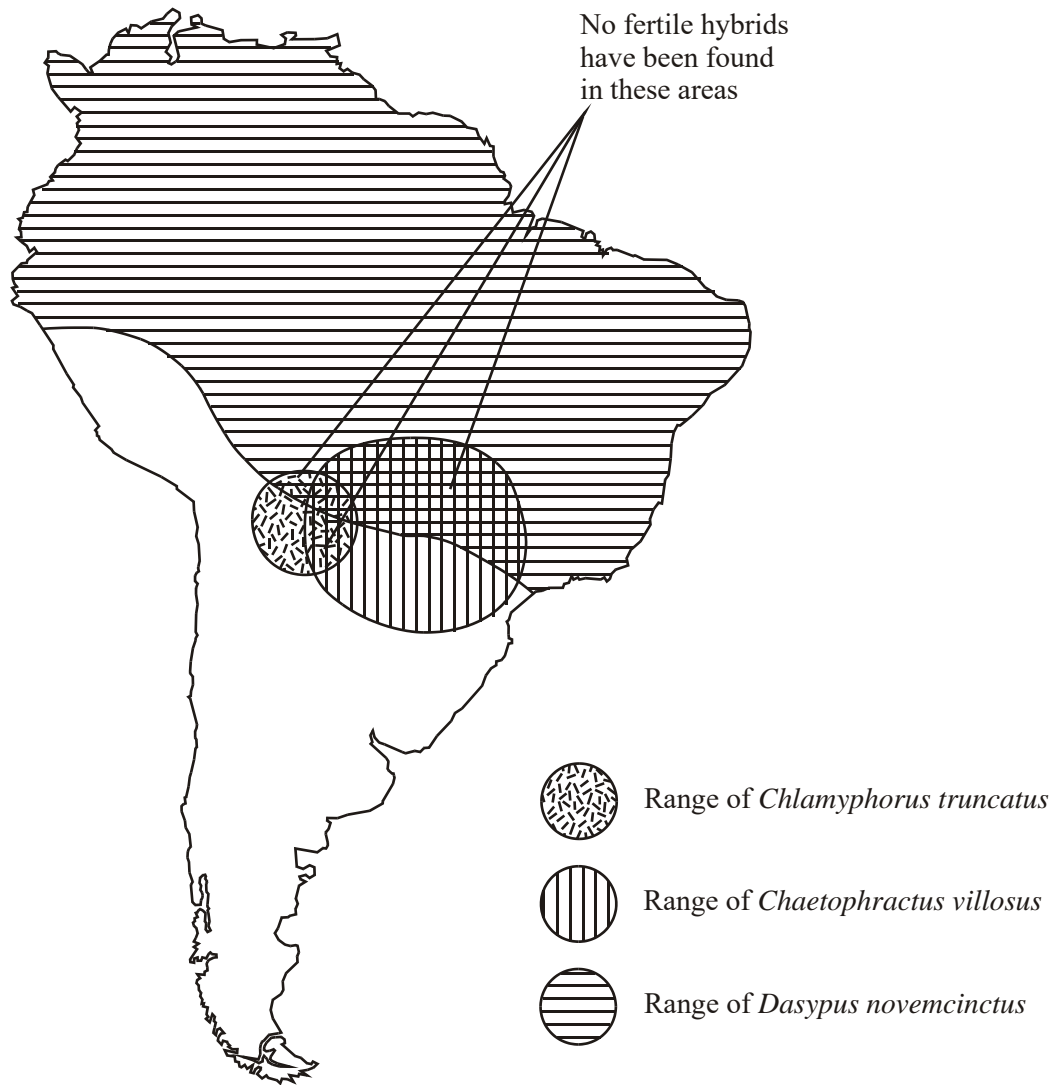

- (a) (i) What evidence in their ranges suggests that the three armadillos belong to different species?

.....

.....

(ii) What further evidence would confirm that the three armadillos belong to different species?

.....  
 .....

(1)

(b) (i) Complete the table to show the classification of *Dasypus novemcinctus*.

Kingdom	
Phylum	Chordata
	Mammalia
	Xenarthra
	Dasypodidae
Genus	
Species	

(2)

(ii) What is the lowest taxonomic grouping that the three species of armadillos can share? Explain your answer.

.....  
 .....  
 .....  
 .....

(1)

(Total 5 marks)



7. Tigers inhabit forests where they feed mainly on large prey animals. Over the past fifty years, there has been extensive deforestation in many areas where tigers are found.

The graph shows the relationship between the prey biomass of an area and the tiger population that the area can support.

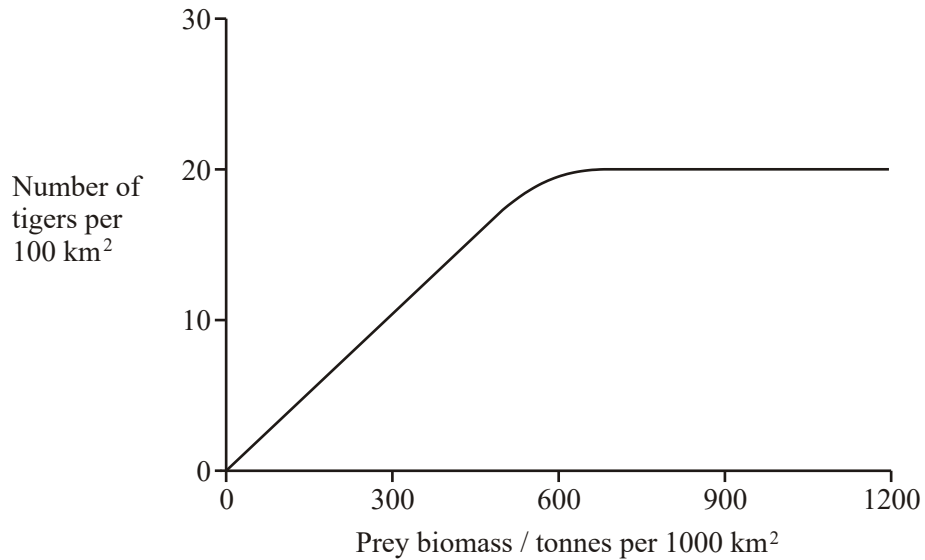

- (i) What is meant by the ecological term *population*?

.....  
 .....

(1)

- (ii) Use the graph to explain how deforestation might cause a reduction in the number of tigers in an area.

.....  
 .....

.....  
 .....

.....  
 .....

.....  
 .....

(3)

(Total 4 marks)

8. Phytoplankton and zooplankton were both found in a lake. Phytoplankton are unicellular protists. Zooplankton are small animals that feed on the phytoplankton.

The biomass of the phytoplankton and zooplankton per cubic metre of water was estimated on several occasions over a period of three months. These data were used to calculate the productivity of the phytoplankton and zooplankton. In this instance, productivity was described as the amount of biomass produced per cubic metre per day.

- (i) What calculation would have to be made to find the productivity of the phytoplankton?

.....  
.....

(1)

- (ii) The ratio of productivity of phytoplankton to productivity of zooplankton per year in this lake was 9.2 : 1. How is this figure consistent with the principles of energy transfer through an ecosystem?

.....  
.....  
.....  
.....

(2)

(Total 3 marks)

9. Finches are small birds. Fourteen species of finch are found on the Galapagos Islands.

- (a) What is a species?

.....  
.....  
.....  
.....

(2)

- (b) Measurements were made of the beak depth of two species of finch (species **A** and species **B**) on different islands. Species **A** is found on island 1, species **B** is found on island 2. Both species are found on island 3. They are thought to have colonised island 3 from islands 1 and 2 respectively. The graphs show the ranges of beak depths of the two species on the different islands.

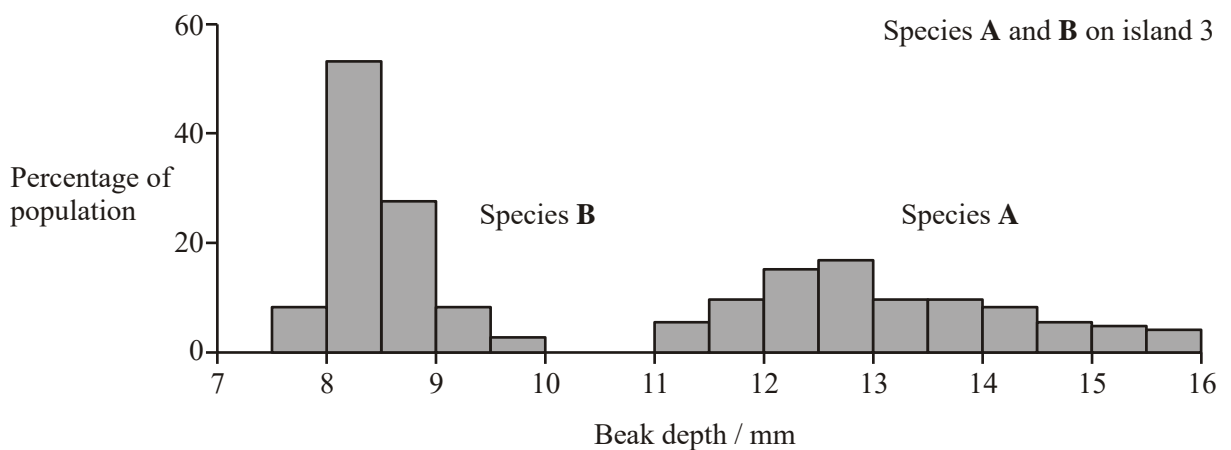
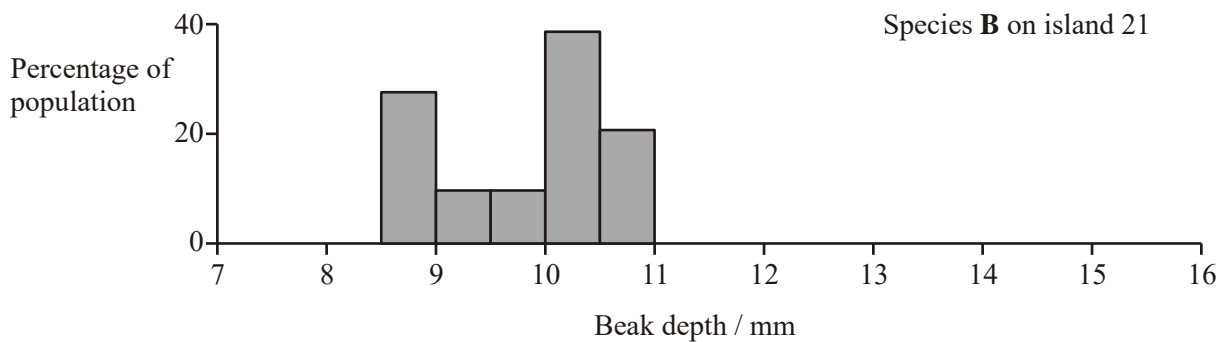
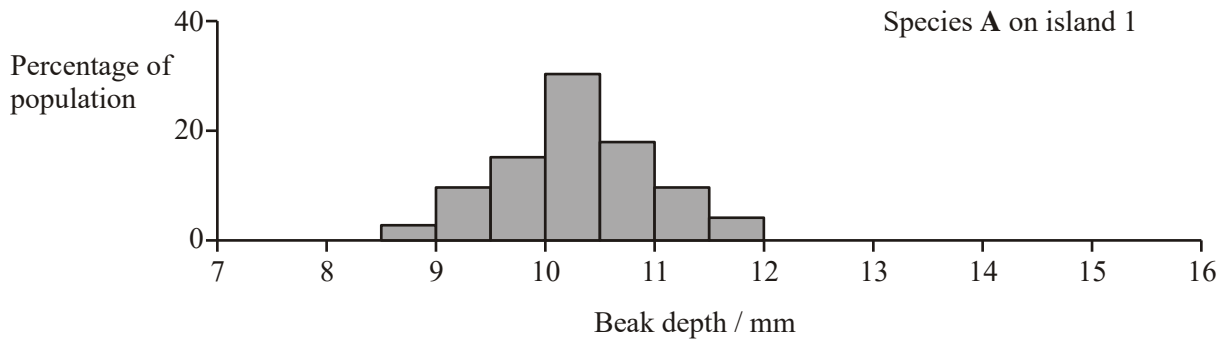

What type of natural selection took place in the populations of both species after they had colonised island 3? Explain your answer.

.....

.....

.....

.....

.....

.....

(3)  
(Total 5 marks)

10. In taxonomy, each of the levels of classification (class, family, genus, kingdom, order, phylum and species) is called a taxon. The diagram represents just three of these levels of classification.

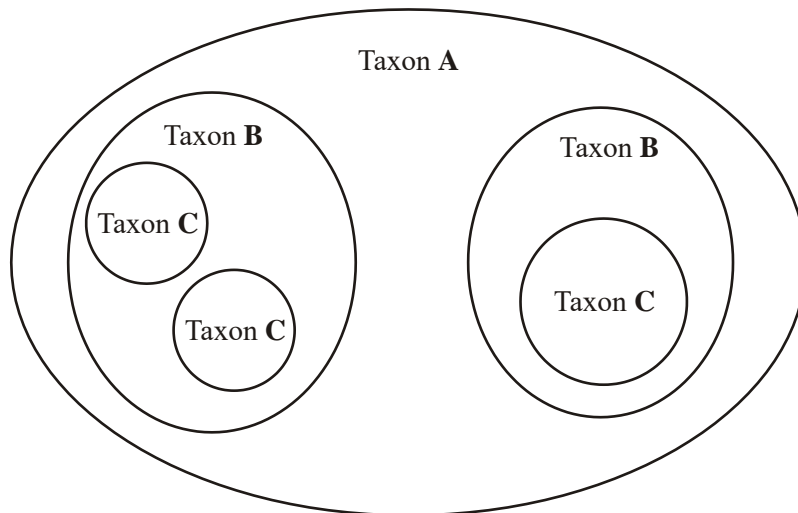

Explain which of these levels of classification could **not** be

- (i) a genus;.....
- .....
- (ii) a phylum.....
- .....

(Total 2 marks)

11. In devising phylogenetic schemes biologists traditionally use as much information about living organisms as possible: their appearance, anatomical organisation, development, mode of nutrition, metabolic pathways, the sequence of subunits making up their DNA, RNA and protein, behavioural interactions and fossil history.

Describe the principles on which the system of classification of living organisms is based.

.....

.....

.....

.....

.....

.....

.....

.....

.....

.....

(Total 4 marks)

12. Complete the following passage.

The classification system of living organisms consists of a hierarchy in which groups are contained within larger groups with no overlap. These groupings are phylogenetic because they are based on the ..... relationship between organisms.

The lion, *Panthera leo*, is classified as belonging to the genus.....

It is recognised as a different.....from the tiger, *Panthera tigris*,

because lions and tigers cannot breed together to produce.....

offspring. All the different genera of the cats are grouped into the.....,

Felidae. Further groupings occur until the largest unit of classification is formed,

the .....

(Total 6 marks)

13. We now know that humans and fruit flies have the same control genes that direct the development of the embryo. These genes have been inherited from a common ancestor. That ancestor lived more than 530 million years ago and probably looked like some small, mud-burrowing worm. Since then, extra genes have been added both to the fly and to us.

Fruit flies and humans belong to different groups within the animal kingdom. Explain how the features of the biological classification system support the idea that animals in different groups have some genes in common.

.....

.....

.....

.....

.....

.....

.....

(Total 3 marks)

14. (a) **Table 1** shows the classification of *Fucus vesiculosus*. Enter the three missing groups in the table.

Kingdom	Protoctista
	Phaeophyta
Class	Phyophyceae
	Fucales
Family	Fucaceae
	<i>Fucus</i>
Species	<i>vesiculosus</i>

**Table 1**

(2)

- (b) Samples of DNA were removed from three species of *Fucus*. The DNA in each sample was separated into its two strands. This single-stranded DNA was then mixed with single-stranded DNA from another sample, either from the same species or from a different species. This allowed sections of DNA with complementary base sequences to join together to form 'new' double-stranded sections. The percentage of doublestranded DNA resulting is shown in **Table 2**.

<i>Fucus</i> species from which DNA was taken, separated into strands, and mixed together		Percentage of double-stranded DNA
<i>F. vesiculosus</i>	<i>F. vesiculosus</i>	99.8
<i>F. vesiculosus</i>	<i>F. serratus</i>	81.3
<i>F. vesiculosus</i>	<i>F. spiralis</i>	85.4
<i>F. serratus</i>	<i>F. spiralis</i>	94.6
<i>F. spiralis</i>	<i>F. spiralis</i>	99.9

**Table 2**

Which **two** of these species seem to be the most closely related? Explain your answer.

.....

.....

.....

.....

.....

(3)  
(Total 5 marks)

15. Read the following passage.

Higher animals seem never to have evolved cellulases. Ruminants, such as cattle, deer and camels, house certain types of bacteria in a four-chambered stomach. Cellulose is digested by the prokaryotes, which possess cellulases. The rabbit, *Oryctolagus cuniculus*, has, like the horse, an enlarged caecum in which cellulose breakdown occurs, also brought about by resident bacteria.

Cellulose is also digested in the intestine of the garden snail, *Helix pomatia*, although, in experiments, extracts of the digestive gland lack cellulase activity. A protoctist, *Trichonympha*, inhabits the intestine of wood-eating termites, and is responsible for their being able to digest cellulose in their diet of wood. Bacteria are also present here, but do not produce a cellulase. Instead they seem to be nitrogen-fixing, which may explain how termites are able to thrive on a diet so low in nitrogen-containing compounds.

- (a) Give the names of two genera mentioned in the passage.

.....

(1)

- (b) Organisms from three kingdoms are mentioned in the passage. Name each of these kingdoms.

.....

(2)

- (c) A garden snail was mated with a snail from a different continent. Offspring were produced. What would you need to know about these offspring to be certain that both parents belonged to the same species?

.....

.....

(1)

(Total 4 marks)



16. Answers should be written in continuous prose, where appropriate. Quality of Written Communication will be assessed in these answers.

In California there are different types of *Ensatina eschscholtzi*, each with a characteristic appearance and found in its own area. They are sufficiently different from each other to be classified as subspecies. These may become new species with time. The map shows the distribution of populations of four subspecies.

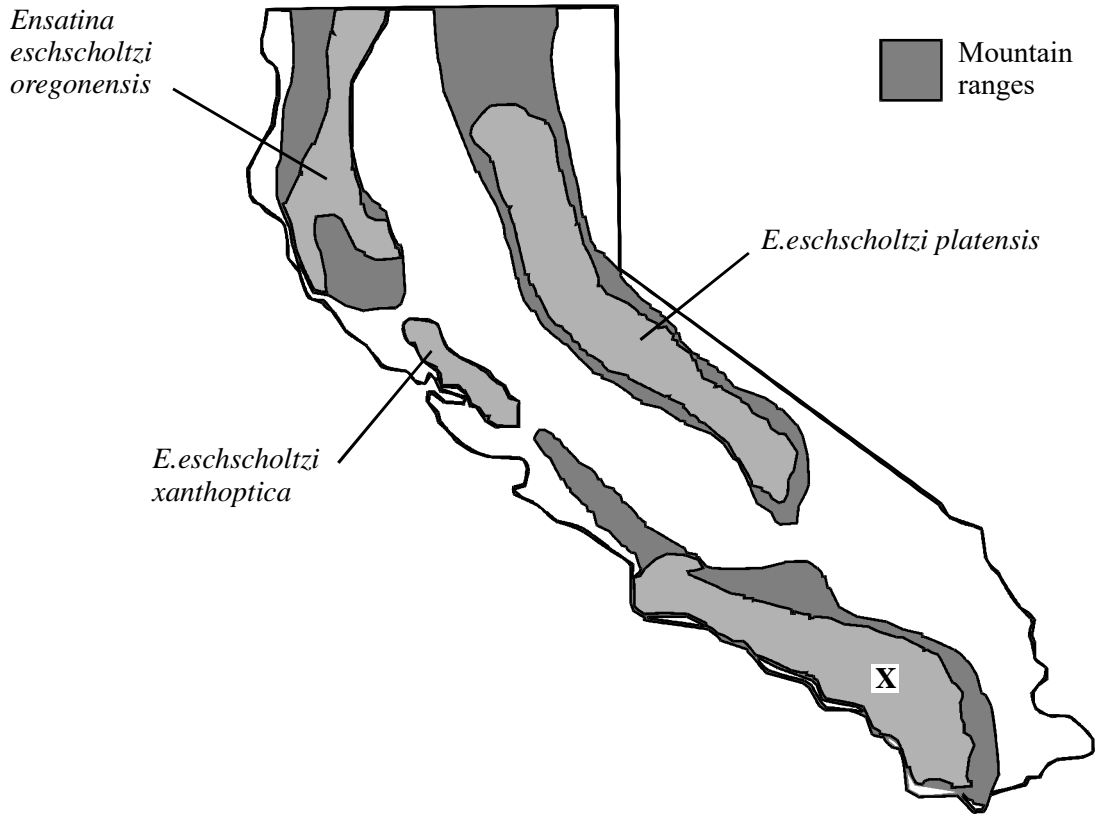

- (i) Suggest how speciation may be occurring in these salamanders.

.....

.....

.....

.....

.....

.....

.....

.....

- (ii) Suggest **one** way in which scientists could find out whether the salamanders from the area marked **X** were a different species from those found in other areas.

.....

.....

.....

.....

(2)

- (iii) Within each subspecies there is a range of phenotypes. Explain the factors that give rise to this variation.

.....

.....

.....

.....

.....

.....

.....

.....

.....

(4)

**(Total 10 marks)**

**17.** This question should be written in continuous prose, where appropriate. Quality of Written Communication will be assessed in these answers.

- (a) Use your knowledge of classification to arrange *class*, *phylum*, *genus* and *family* in order of decreasing number of species.

largest number of species			smallest number of species
.....	.....	.....	.....

(1)

- (b) The diagram shows an amoeba. This is a single-celled organism.

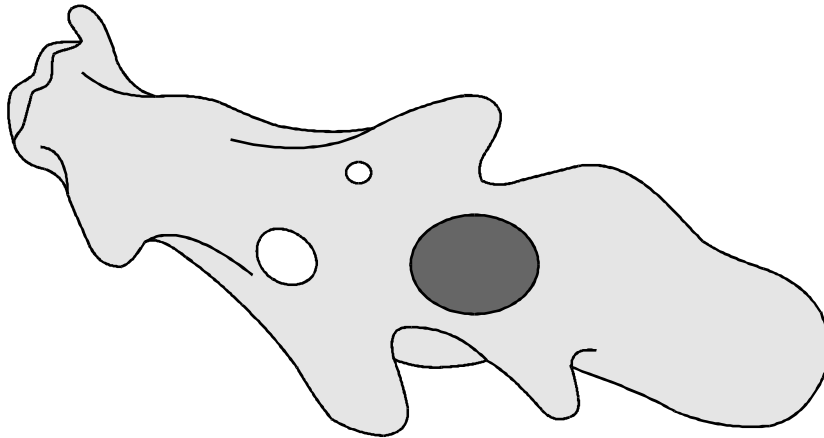

Amoeba is classified as a protist. Giving a different answer in each case, explain why it is **not**

- (i) a prokaryote;

.....  
 .....

- (ii) a fungus.

.....  
 .....

(2)

- (c) Cytochrome c is a protein involved in one of the reactions of aerobic respiration in a mitochondrion. The molecular structure of cytochrome c from different species has been analysed. More similarities are present in the structure of cytochrome c in closely related species than in distantly related species.

- (i) Explain what is meant when two species are described as being *closely related*.

.....  
 .....

(1)

- (ii) A difference in the molecular structure of cytochrome c may arise in a small population that becomes geographically isolated. Explain how the difference may arise and how it may spread in the population.

.....

.....

.....

.....

.....

.....

.....

.....

.....

(4)  
(Total 8 marks)

18. (a) The mammals form a class called the Mammalia within the animal kingdom. The grey wolf is a species of mammal. **Figure 1** shows the groups within the Mammalia to which the wolf (labelled **W**) belongs.

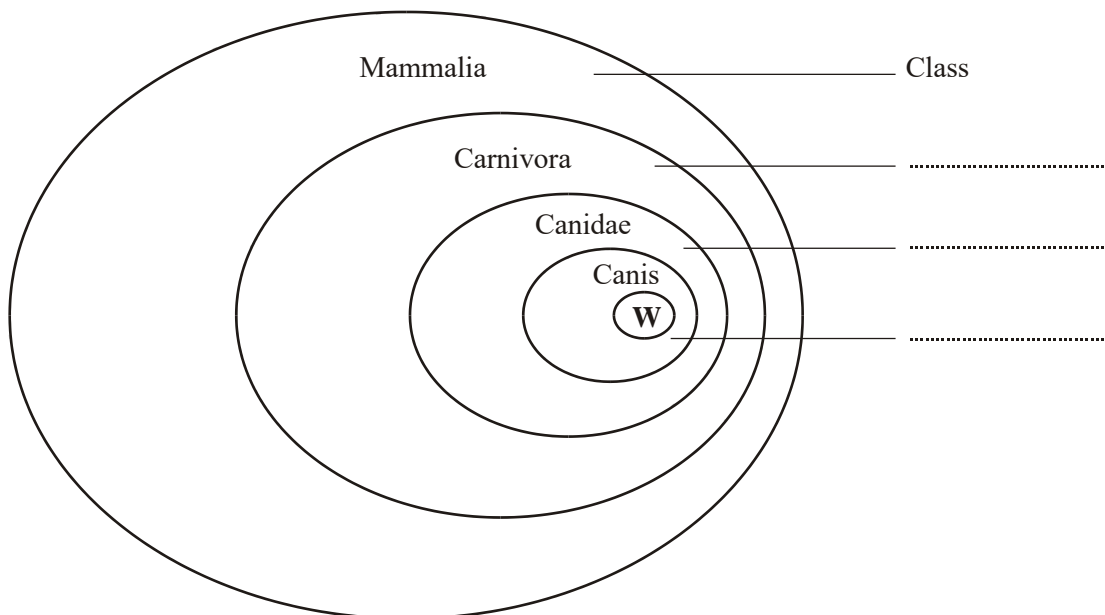
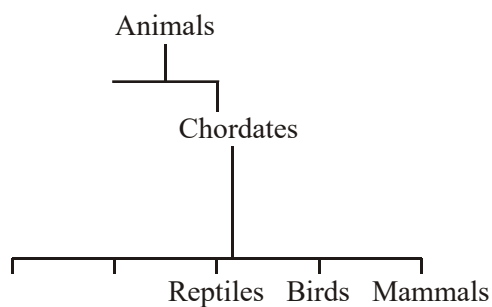

**Figure 1**

(i) Label **Figure 1** to show the names of the groups. (2)

(ii) The lion, *Panthera leo*, belongs to another group in the Carnivora, called the Felidae. Add this information to **Figure 1**, using the letter L to represent the lion species. (1)

(b) The diagrams show two systems of classification of mammals. **Figure 2** shows a simple hierarchy. **Figure 3** shows a phylogenetic system.



**Figure 2**

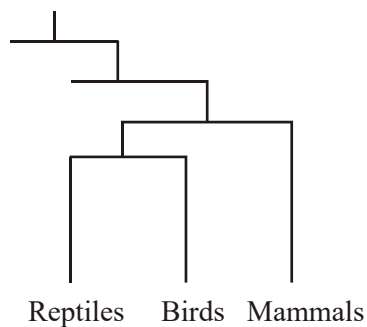

**Figure 3**

(i) What is meant by a hierarchy?

.....  
 .....

(1)

(ii) By reference to **Figures 2** and **3**, explain how a phylogenetic system differs from a simple hierarchy.

.....

.....

.....

.....

.....

.....

(3)  
(Total 7 marks)

**19.** (a) Explain the principles which biologists use to classify organisms into groups.

.....

.....

.....

.....

.....

.....

(3)

Cytochrome c is a protein with about 100 amino acids and is present in all eukaryotic organisms. It has the same three-dimensional shape in all species, but only 30 of the amino acids are the same in all species. The amino acid sequence of cytochrome c has been used to construct the phylogenetic tree shown below.

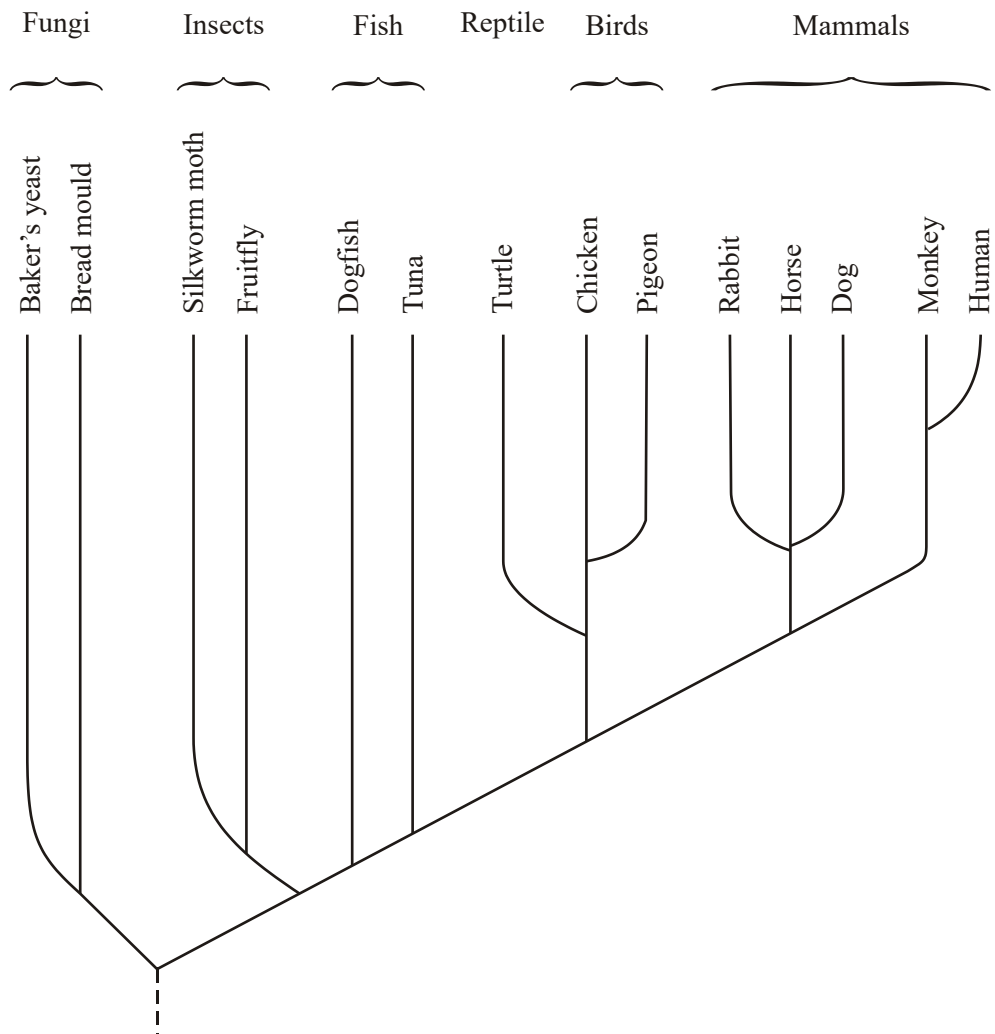

(b) Name the kingdoms represented in this phylogenetic tree.

.....

(1)



(c) What does the phylogenetic tree show about the evolutionary relationship between fungi and insects?

.....

.....

.....

.....

(2)

- (d) Suggest how information on amino acid sequences is used to construct a phylogenetic tree.

.....

.....

.....

.....

(2)

- (e) Suggest **one** advantage and **one** disadvantage of using cytochrome c to construct a phylogenetic tree.

Advantage .....

.....

Disadvantage .....

.....

(2)  
(Total 10 marks)

20. (a) The cheetah, *Acinonyx jubatus*, and other cat species belong to the family Felidae. Complete the table to show the classification of the cheetah.

Kingdom	Animalia
	Chordata
	Mammalia
	Carnivora
Family	Felidae
Genus	

(2)

- (b) This system of classification is described as hierarchical. Explain what is meant by a hierarchical classification.

.....

.....

(1)

(c) Despite differences in form, leopards, tigers and lions are classified as different species of the same genus. Cheetahs, although similar in form to leopards, are classified in a different genus.

(i) Describe **one** way by which different species may be distinguished.

.....

.....

(1)

(ii) Suggest **two** other sources of evidence which scientists may have used to classify cheetahs and leopards in different genera.

1 .....

.....

2 .....

.....

(2)  
(Total 6 marks)

21. (a) *Class, family, genus* and *kingdom* are terms used in classifying organisms.  
Write the terms in the correct sequence.

Largest number  
of species

Smallest number  
of species

.....

.....

.....

.....

(1)



- (b) Cytochrome c is a protein. The table shows the sequence of the last six amino acids in cytochrome c in humans and three other animals.

<b>Animal</b>	<b>Sequence of amino acids in cytochrome c</b>
Human	lys-ile-phe-ile-met-lys
	lys-th-rphe-val-glu-lys
	lys-ile-phe-ile-met-lys
	lys-ile-phe-val-glu-lys

- The three other animals are a monkey, a fish and a horse.
- One of the three is in the same order as humans.
- Two are in the same class.

- (i) Complete the table to show the animal from which each sample of cytochrome c was taken.

(1)

(ii) Explain your answer.

.....

.....

**(1)**

(c) DNA hybridisation shows similarities between DNA samples. Explain why

.....

.....

.....

.....

.....

.....

(3)  
(Total 6 marks)

22. (a) What is a species?

.....

.....

.....

.....

(2)

The courtship behaviour of male fruitflies has several components. The diagram shows the courtship sequences of males from two closely related species of fruitfly.

**Species A**

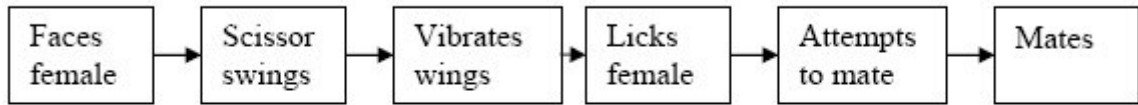

**Species B**

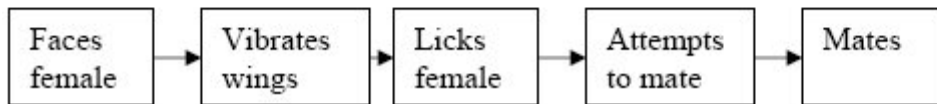

(b) Suggest how the courtship sequences provide evidence that

(i) the fruitflies are separate species

.....  
.....

(1)

(ii) the species are closely related.

.....  
.....

(1)

- (c) During courtship males of both species vibrate their wings. This produces a sound. Explain how this sound helps to ensure that the female mates only with a male of the same species.

.....

.....

.....

.....

(2)  
**(Total 6 marks)**



23. (a) An order is a taxonomic group. All seals belong to the same order. Name **one** other taxonomic group to which all seals belong.

.....

(1)

(b) The diagram shows how some species of seal are classified.

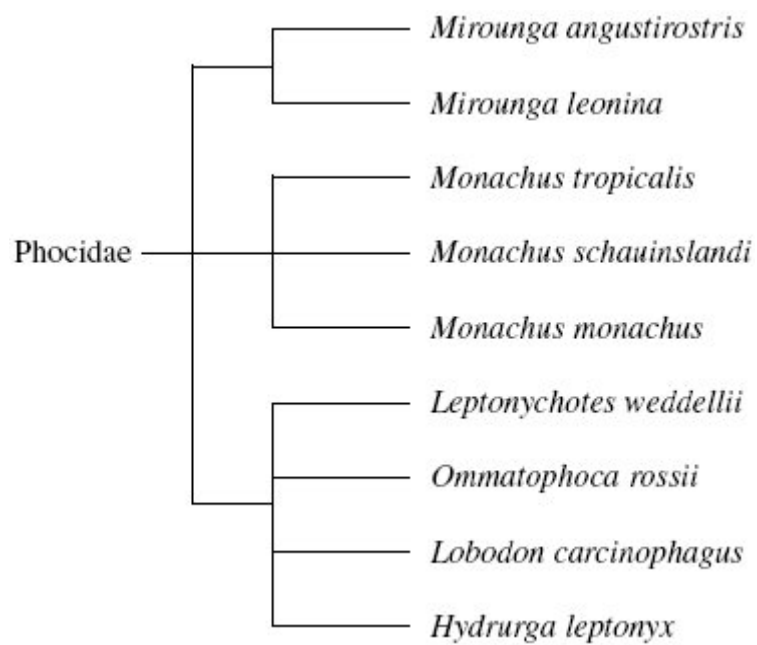

- (i) How many different genera are shown in this diagram?

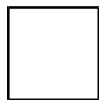

(1)

- (ii) All the seals shown in the diagram are members of the Phocidae. Phocidae is an example of a taxonomic group. Of which taxonomic group is it an example?

.....

(1)

- (iii) The diagram is based on the evolutionary history of the seals. What does the information in the diagram suggest about the common ancestors of *Mirounga angustirostris*, *Mirounga leonina* and *Monachus tropicalis*?

.....

.....

.....

(1)

(c) A species of seal shows genetic diversity. Explain what is meant by genetic diversity.

.....

.....

**(1)**

- (d) In the late 18<sup>th</sup> century, the population of northern elephant seals was estimated to be about 150 000. These seals lived in different colonies in different places. The seals were then hunted. By 1910, the total population had fallen to under 100. All these seals lived in a single colony on one island. Hunting then stopped. Numbers increased and there are now approximately 150 000 seals living in many different colonies.

Use this information to explain

- (i) what is meant by a genetic bottleneck

.....

.....

.....

.....

(2)

- (ii) how you would expect the founder effect to have influenced the genetic diversity of northern elephant seals after 1910.

.....

.....

.....

.....

(2)  
**(Total 9 marks)**



24. (a) A fish uses its gills to absorb oxygen from water. Explain how the gills of a fish are adapted for efficient gas exchange.

.....

.....

.....

.....

.....

.....

.....

.....

.....

.....

.....

.....

.....

.....

.....

.....

(6)

Mackerel live in the surface waters of the sea. Toadfish live on the seabed in deep water.

- (b) The concentration of oxygen is higher in the surface waters than it is in water close to the seabed. Suggest why.

.....

.....

.....

.....

(2)

- (c) The graph shows oxygen dissociation curves for toadfish haemoglobin and for mackerel haemoglobin.

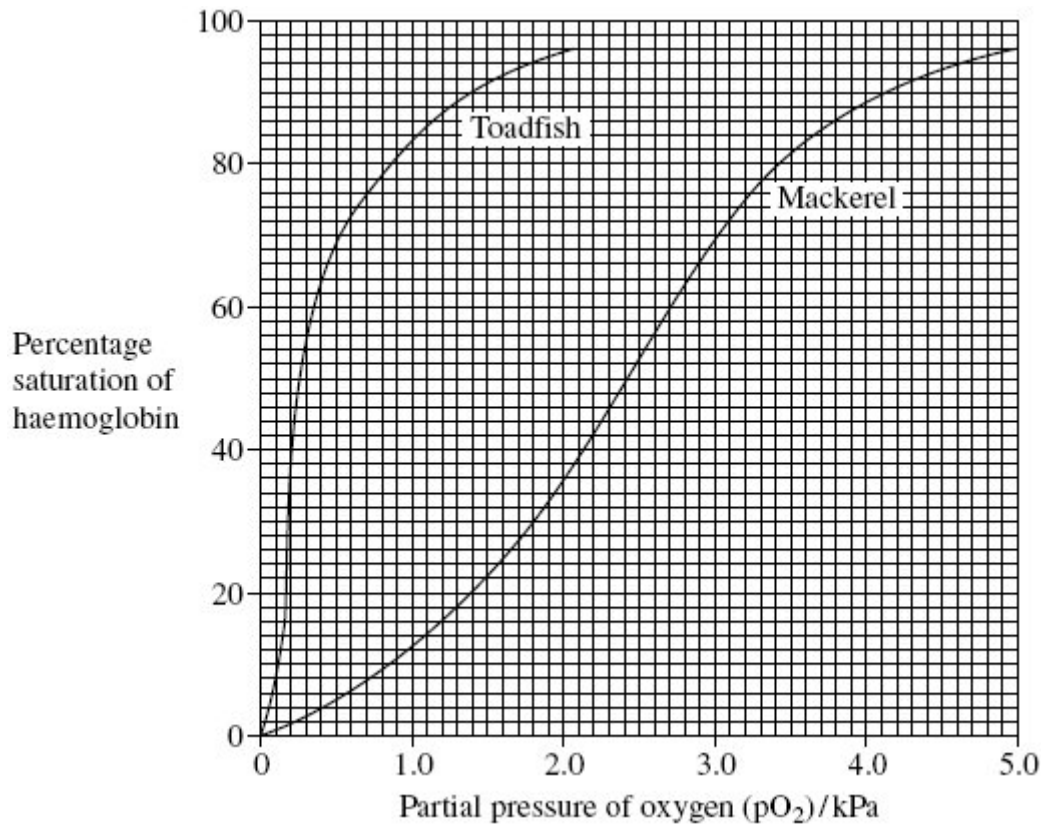

Explain how the shape of the curve for toadfish haemoglobin is related to where the toadfish is normally found.

.....

.....

.....

.....

(2)

- (d) Scientists analysed the sequence of amino acids in one polypeptide chain in the haemoglobin of four different species of ape. The only difference they found affected the amino acids at three positions in the polypeptide chain. Their results are shown in the table. The letters are abbreviations for particular amino acids.

Species	Position 87	Position 104	Position 125
Chimpanzee	T	R	P
Bonobo	T	R	P
Gorilla	T	K	P
Orang utan	K	R	Q

- (i) What information do the data in the table suggest about the relationships between the chimpanzee, the bonobo and the gorilla? Explain your answer.

.....

.....

.....

.....

(2)

- (ii) Hybrid DNA was made from the gene for chimpanzee haemoglobin and the genes for the haemoglobin of the other three species of ape. Which of the three samples of hybrid DNA would separate into two strands at the lowest temperature? Explain your answer.

.....

.....

.....

.....

.....

.....

(3)

(Total 15 marks)